Energy: The Next Frontier

NYS Advanced Energy Research and Technology Center

Dr. Yacov Shamash

Vice President for Economic Development and Dean, College of
Engineering and Applied Sciences, Stony Brook University

Gen5 Ceramic Consortium 2006

Garden City, Long Island, N.Y.

September 7, 2006





The **mission** of this Center will be to forge partnerships between universities, industries, and national laboratories in order to develop reliable, economical, and plentiful sources of energy that will ensure sustained economic development of the region without impairing the natural environment.

Objectives

- **Establish a broad based interdisciplinary research program** which integrates fundamental science, nanotechnology, and engineering to design next generation advanced energy systems - renewable energy sources, molecularly engineered traditional fuels, cutting edge fuel cell technology.
- **Build full scale demonstration and testing units which will evaluate new technologies;** solar, biomass, hydrates, and cogeneration with traditional fuels.
- **Design a working “green” power plant** that incorporates wireless technology with fundamental research to evaluate the economic factors of zero emissions power generation and establish standards for safety and environmental impact.
- **Develop accurate simulation models** of the power grid to optimize the distribution network, provide alternatives in case of local failures, and provide early warning of sabotage, leaks, or terrorist infringement.
- **Explain energy policy and emerging technologies to the public.** this includes sponsorship of national and international conferences for experts on energy related research, workshops to inform the public of energy issues, outreach to schools through special programs designed for k-12 teachers and their students

AERTC Participating Institutions

Academic Institutions



SCC, NYIT, Hofstra, SUNY-Westbury, SUNY-MMA

Laboratories



Industries



Invision



Anorad

Energy research will be driven by an alliance of universities, laboratories, and companies.

Improving the present: continuing education programs with SUNY Maritime



LNG terminal and depot in Louisiana

SUNY Maritime trains 98% of the ship captains that deliver LNG's into East Coast terminals.



Cadets at SUNY Maritime in basic training. The Empire State training ship is above.

Ensuring the future: Energy Education

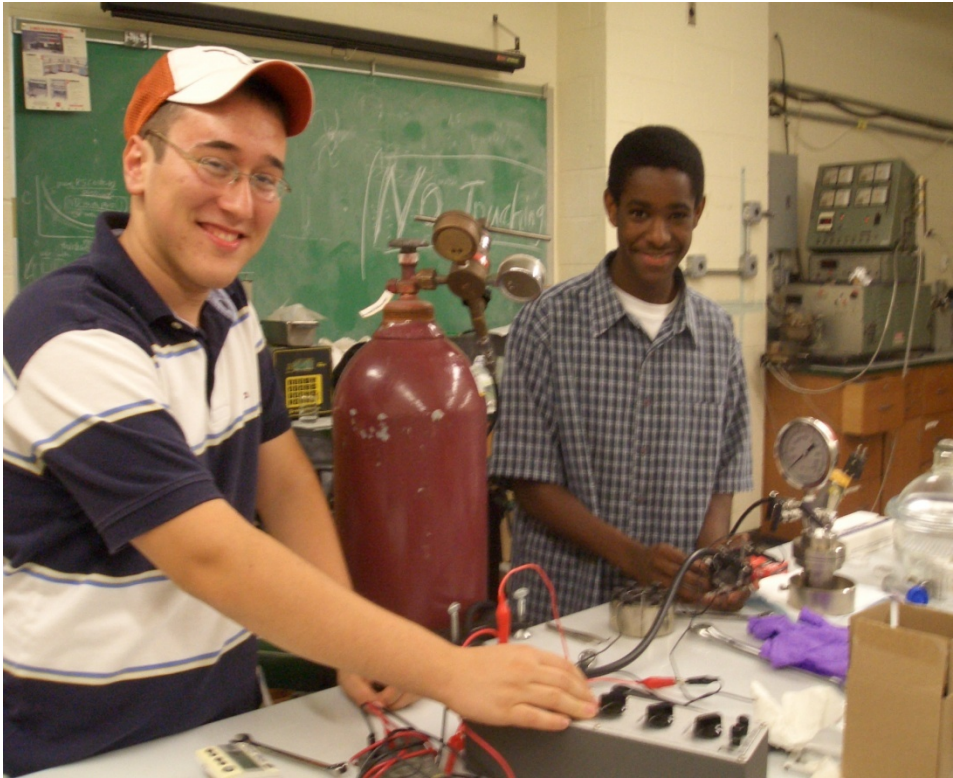

Platinum Nanoparticles: From Hydrogen Storage to Cancer Treatment



**66th Annual STS (2006-2007)
Finalists
Daniel Scott Katz**

SCIENCE
SERVICE



Ergerie Eugenie, Uniondale High School, Uniondale, New York
Daniel Katz, HAFTR High School, Cedarhurst New York experiment with
fuel cell design during a summer high school research program at Stony
Brook University.

AERTC Organization of the Energy Center Overview

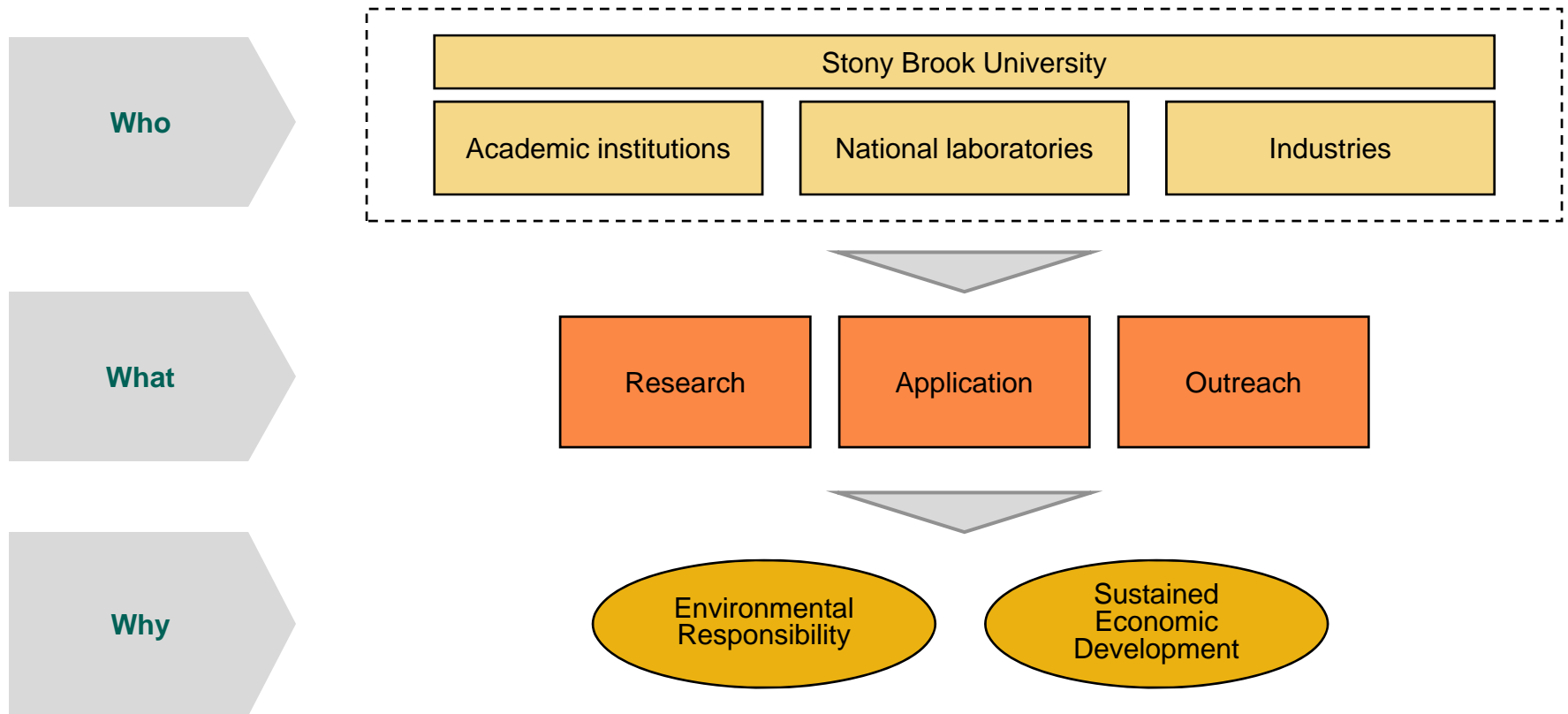

Leveraging existing capabilities and partnerships, the energy center will promote clean and economical energy through research, application, and outreach efforts.

Organizational Overview

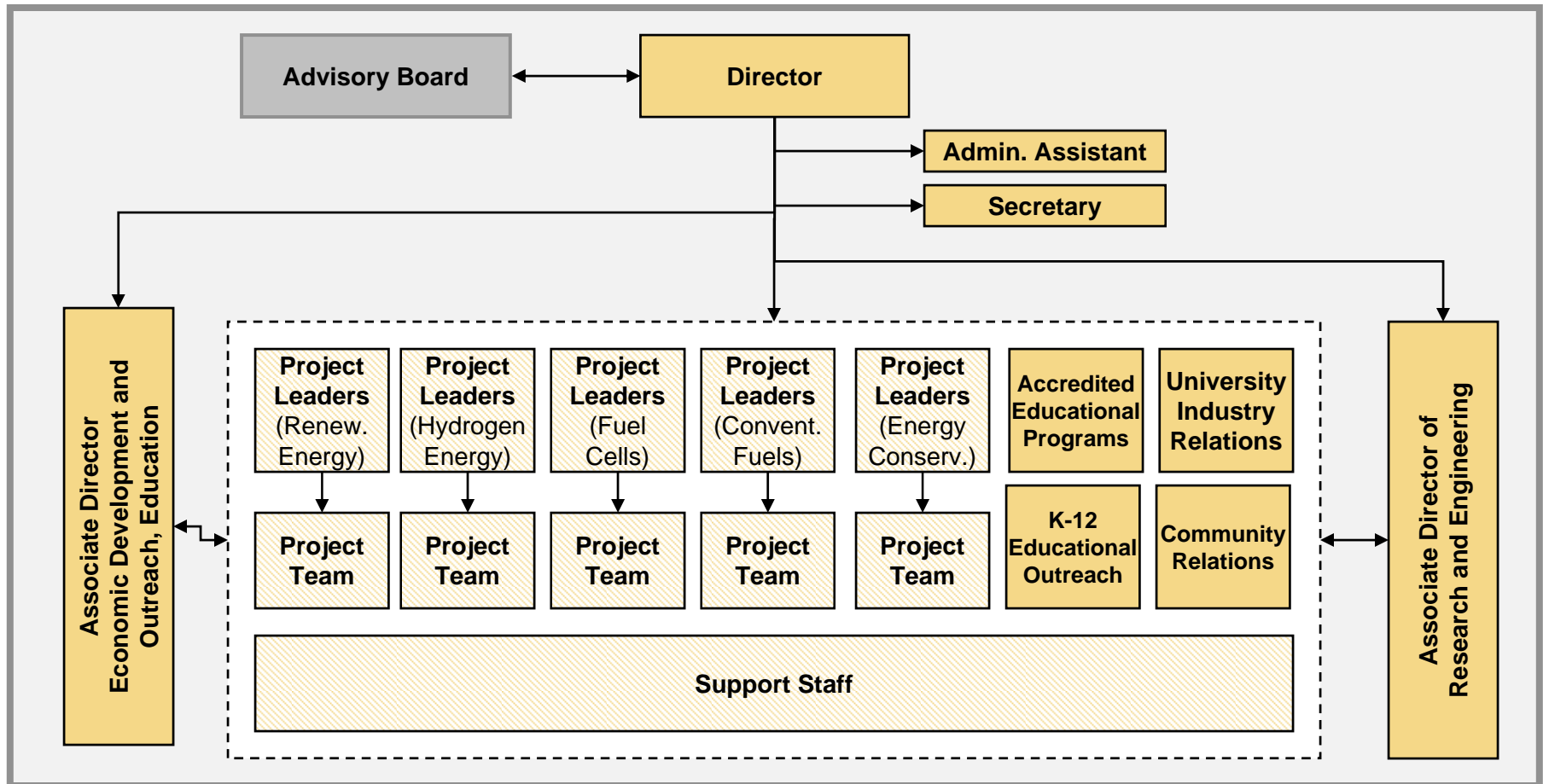

A director, with the counsel of the advisory board, will oversee the center's initiatives. Associate directors, one for outreach, education, and economic development and another for research, technology and engineering, will interface with the five focus groups

Establishment of Advisory Committees

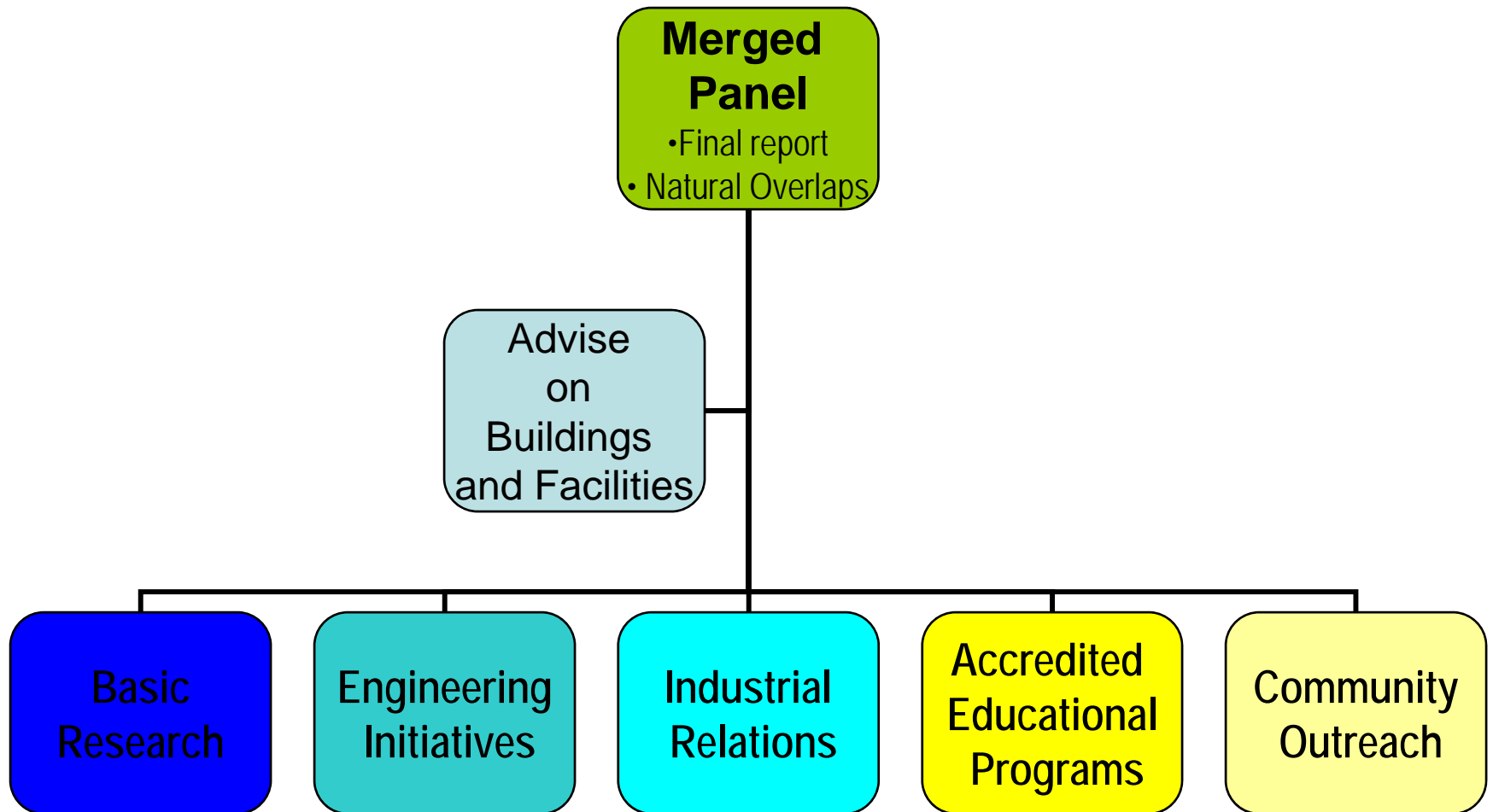

Fundamental Research : Summary

Members:

- ***Doon Gibbs (BNL)**
- ***Fu Pen Chiang (USB)**
- Clare Grey(USB)
- Emilio Mendez(USB/BNI)
- Kosta Likharev (USB)
- Ben Chu (USB)
- Peter Kahn(USB)
- Grigory Belenki (USB)
- Harry Gafney (QC-CUNY)

- Existing strengths:
Nanotechnology
- Define distinct focus areas for fundamental research within AERTC.
Biofuels, photovoltaics, portable energy, optimization conventional fuels, catalysis, cogeneration, process modeling and simulation.
- Identify existing major instrumentation: **BNL Nanocenter (CNF), Supercomputer**
- Suggest new facilities:
Nanofabrication facility and technology testing center.

Engineering Initiatives Summary

Members:

- *Ralph James (BNL)
- *Serge Luryi (USB)
- Jon Longtin (USB)
- Hazem Tawfik (Farmingdale)
- Steve Eber (Keyspan)
- Cindy Lee (MSRC)
- Kalle Levon (Poly)
- Fritz Henn (BNL)

- Focus areas for engineering research: **Employ Nanotechnologies:** Bio-fuels and Bio-Inspired Energy generation systems, hydrogen storage, portable energy, CO₂ sequestration, optimization of fossil and coal fuels, catalysis, modeling and remote sensing.
- Identify major new facilities to be constructed in the new AERTC building : **New Technology Testing Facility, Biofuel Reactor Enclosure, Organic Synthesis Laboratory, Nanofab for electronics components and sensors.**

Industrial Relations: Summary

Members:

- *Satya Sharma (USB)
- *Mike Furey (BNL)
- Clive Clayton (USB)
- Bruce Germano (LIPA)
- Peter Shkolnikov (USB)
- Jack Harran (Keyspan)
- David Winchester (HIA)

Address two major challenges:

- I. Match technology developed in the laboratory with needs/problems of industry.*
 - Need to develop a plan which will make BNL user facilities i.e. the Center for Functional Nanomaterials, available to industry.
 - Build prototype testing and development facility in “real world applications”.
 - Consider expansion to house incubator facility.
- II. Develop Uniform IP protocols for all members,*
 - **Very difficult task** since the IP policies vary greatly between private, state, and federal tax levy institutions.
 - Issues must be resolved immediately, *before* large research efforts are initiated and funding is raised from these different sources.
 - Must seek the assistance of qualified legal help.

Accredited Educational Programs

Members:

- *Marjane Issapour (Farmingdale)
- *Gary Halada (USB)
- Serdar Elgun (Farmingdale)
- Anthony Palmietti (Maritime)
- Sam Yahalom (Maritime)
- John Kincaid (USB)

- Establish accredited degree programs in energy at the graduate and undergraduate level.
- Develop teacher training, workforce development, and continuing education programs in energy.
- Design distance learning curriculum.

Community Outreach: Summary

Members:

- *Pat Malone (USB)
- *Jack Kramer (Keyspan)
- *Melanie Krieger (POB School)
- Sam Yahalom (Maritime)
- Dave Ferguson (USB)
- Miriam Dietsch (Farmingdale)
- Yelleshpur Dathatri (Farmingdale)
- Ken White (BNL)
- David Manning (Keyspan)

Challenge: Identify the Audience and Plan to Meet their Needs and interests

Future Generations: Sustain

- Develop enrichment programs for introducing energy into the K-12 curriculum.
- “Intel” like science competitions in energy.
- Teacher research and training courses.

General Public:

- Public forums :museums, libraries, senior centers, NGO.
- Web resources.
- Writing and disseminating literature.

Politicians:

- Provide advice on “hot button” topics.
- Assist in drafting policy
- Sponsor workshops.

Recommendations of the advisory committee:

- The building should be open, airy, and have wide public access areas which encourage interdisciplinary interactions between scientists.
- The lobby should accommodate a public information areas, possible a small energy museum and showcase area.
- Research space should reflect the types of laboratory installations that will meet the needs of the research focus groups of the center.
 - Organic synthesis
 - Bio-fuels greenhouse and Type 2 Micro-organism handling facility
 - Nanofabrication
 - Modular Systems Indoor/outdoor Large Testing Bay
 - Environment/ Nanotechnology cross cutting themes
- Since new research directions are emerging, the space must be versatile in order to accommodate these changes.

•Technology Based
Research & Development
Site

•Promotion of Interaction
Amongst like Minded
Science

•Foster collaboration via
shared facilities and
amenities

•AERTC; 50 permanent,
and 50 visiting
researchers & staff

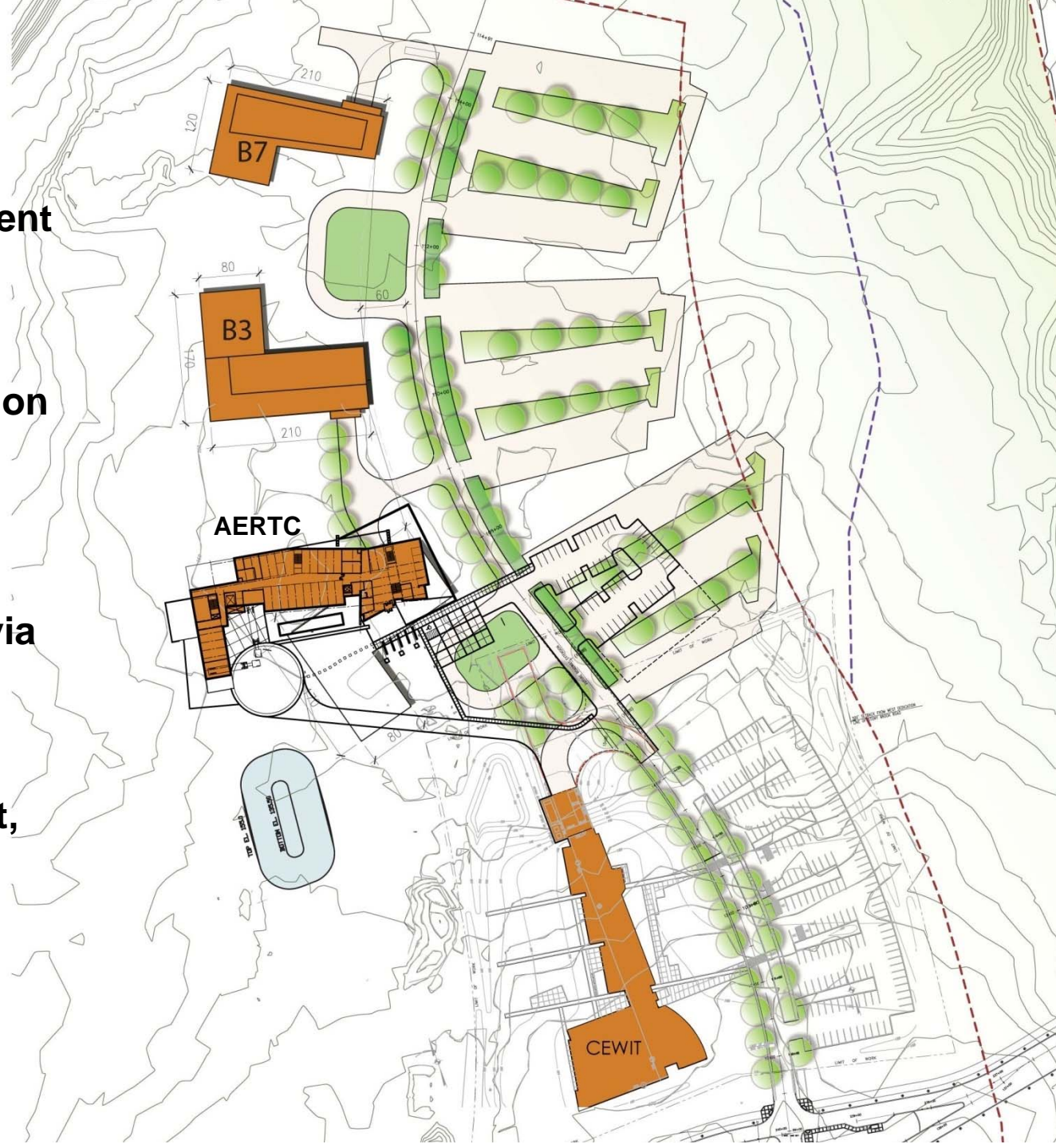

Mission:

- Encourage Collaboration and Interaction with Private Development
- Separate Labs from Offices

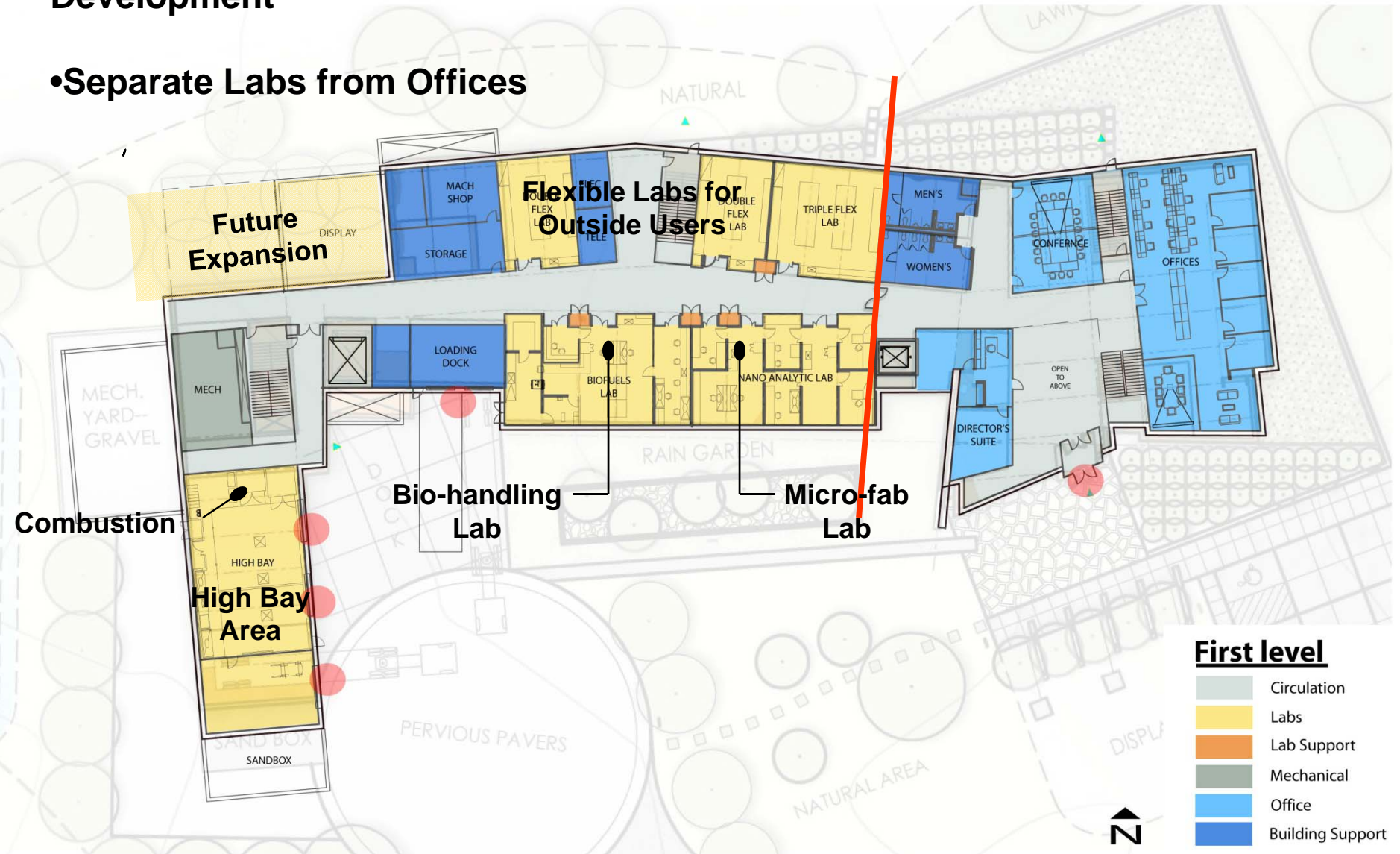

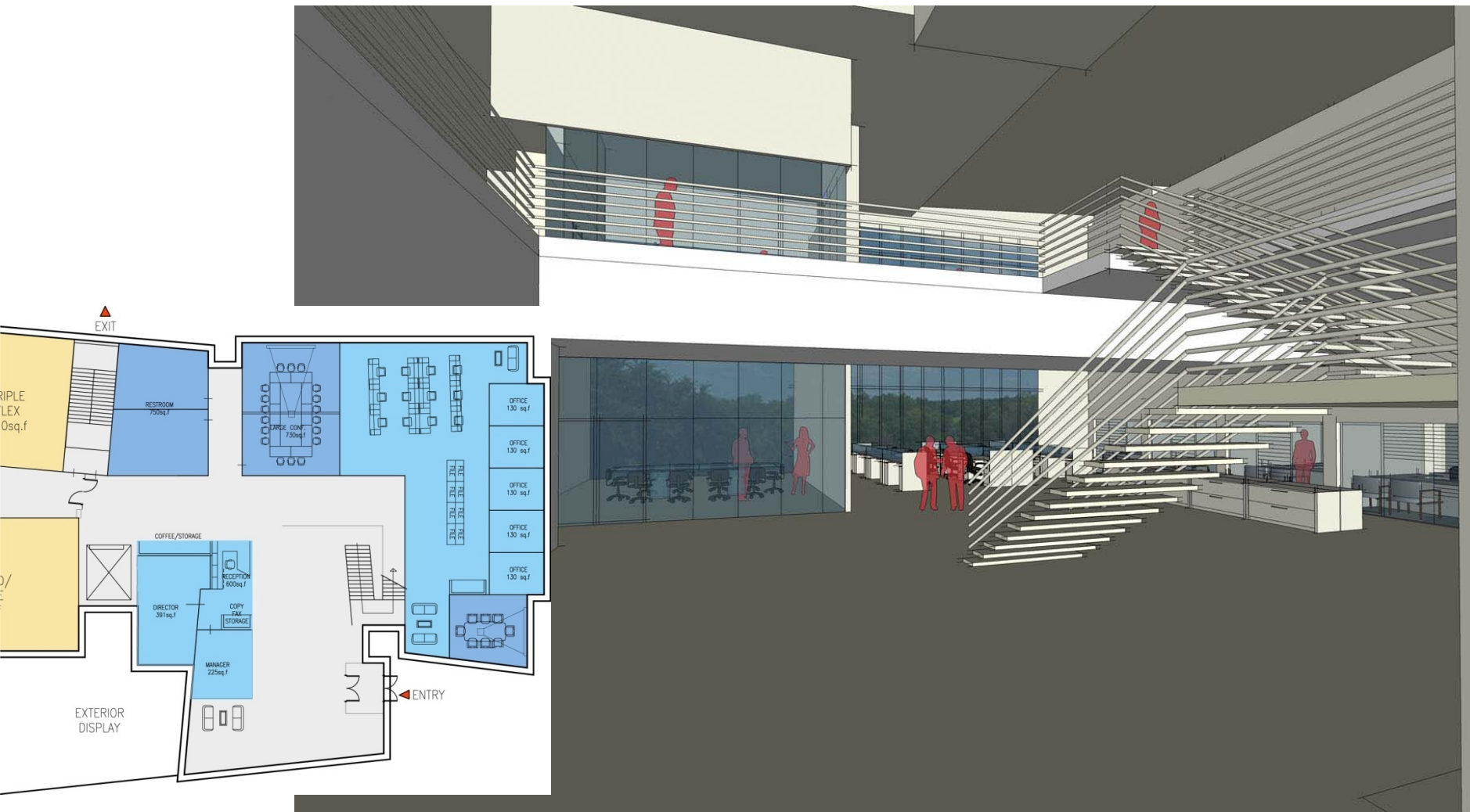

First Floor – Lobby/Entry

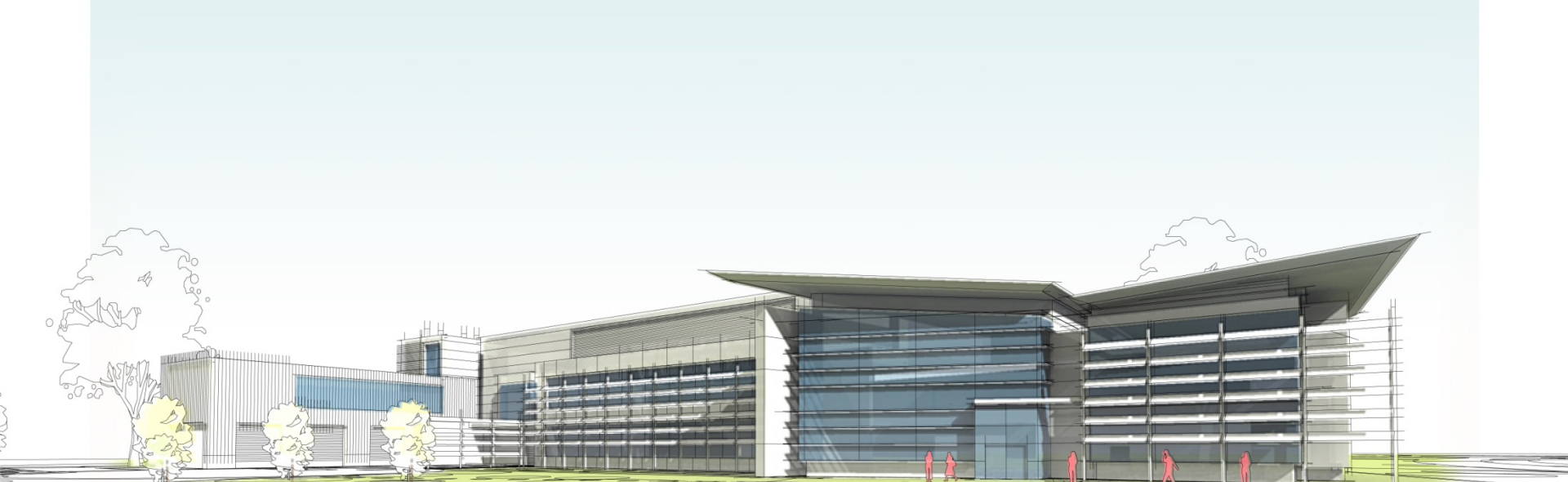

Front lawn and Lobby: Museum and exhibit areas.

Platinum Standard Building

- Limited parking spaces
- Solar power co-generation
- Waste water storage
- Exposure and vegetation to conserve energy



Department of Energy NanoSummit: Nanoscale Science and Our Energy Future

Emerging research opportunities in nanoscale science and technology

Wardman Park Marriott
2660 Woodley Road, NW, Washington, DC
June 23-24, 2004

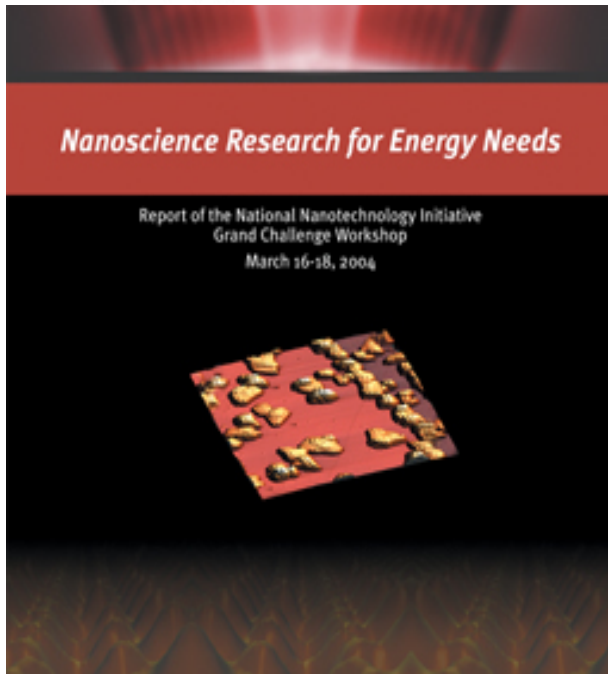

Identification of **nine** research targets in energy-related science and technology in which **nanoscience** is expected to have the greatest impact:

- **hydrogen** production
- Highly selective **catalysts** energy efficient manufacturing
- Efficient and Inexpensive harvesting of **solar energy**
- **Solid-state lighting** for lower power consumption
- Super-strong, non-flamable **light-weight materials**
- Reversible **hydrogen storage** materials operating at ambient temperatures
- **Power transmission lines** capable of 1 gigawatt transmission
 - **Low-cost fuel cells**, batteries, thermoelectrics, and ultra-capacitors.
- **Energy Harvesting** based on the efficient and selective mechanisms of **biology**.

Selected Current Energy Research Projects

- Micro/Nano Mechanics Studies of Sandwich Foam Composites
- Hydrogen Storage and Quantum Level Calculations
- Lighting Technologies
- In-Situ Monitoring of Gases and Pollutants
- Electric Load Forecasting
- Methane hydrate formation
- Photovoltaic Cells for Electric Power Generation
- Combustion Process
- Laser Fusion and Turbulent Mixing
- Nanotechnology and Chemical Sensing
- Alkaline Batteries for Primary Batteries
- Lithium Batteries for High-Power Applications
- Solid Oxide Fuel Cells: Studies of Ionic Conductivity
- Thermal Spray Center for Fuel Cells and Engines
- Environmental Nanotechnologies for Clean Energy Applications
- Water-Air Quality Sensing Project (WASP)
- Fuel Cells
- Fuel Injection into the Plasma Reactor (ITER)
- Thermosetting Polymers as Lighter and Tougher Materials
- Internal Combustion Engine
- Thin-Film Photovoltaic Reliability and Lifetime Assessment
- Extremely Low-Power Hybrid Silicon/Nanoelectronic Circuits
- Oxide Nanomaterials for Energy Applications
- Measurement of Carrier Recombination Parameters in III-V Compounds for Photovoltaic Cell Design Optimization
- Internal Combustion Engine
- Bio-inspired Smart Green Building
- Nanofibrous Membranes for Energy Applications
- Harvesting Wave and Tidal Energy
- Surface Metrology for PV Wafers
- Wafering and Manufacturing of Photovoltaic Solar and Thermal PV Cells

Methane Hydrate: A clean alternative fuel

T. Koga, M. Rafailovich (USB), S. Satija (NIST), J. Jerome (SCC), D. Mahajan (BNL)

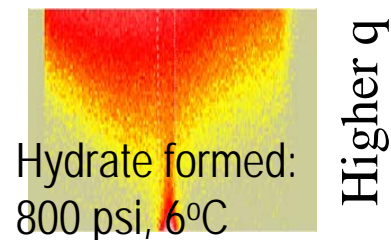
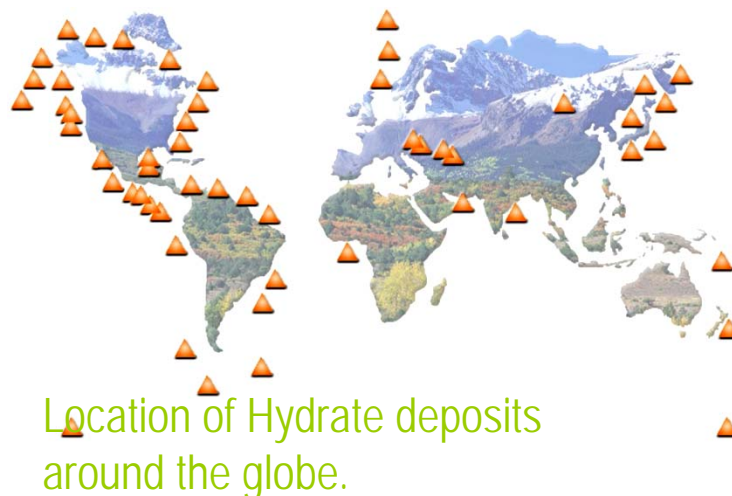
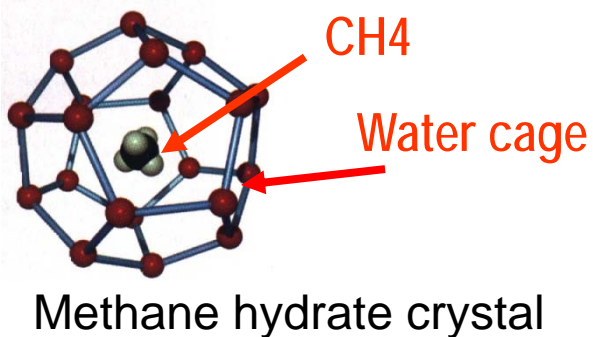

Advantages:

- 20,000 trillion cubic meters of methane stored in the underwater deposits.
- Quantity is larger than all of the current fuel sources !!
- Hydrates uniformly distributed geographically, minimize political tensions.

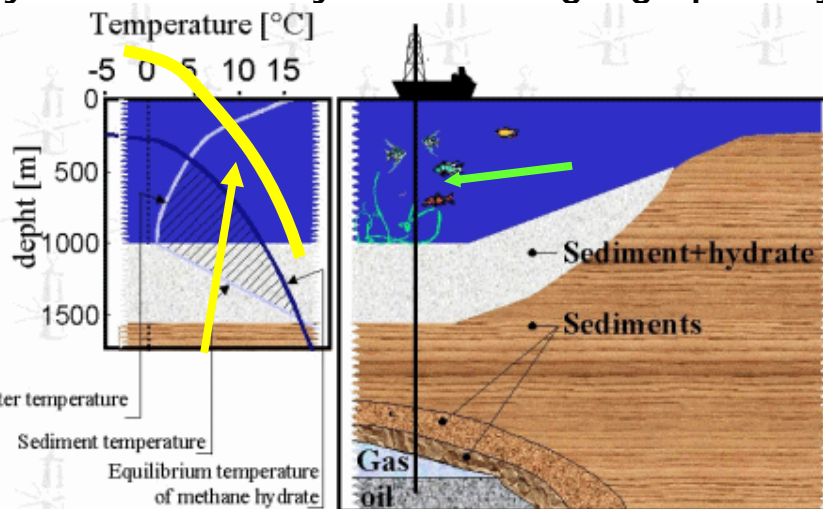

The challenge:

- Stable at low Temp (4 °C) and high P (~800 PSI)
- Must be mined from under the ocean floor .
- Very hard crystals. Known to foul mining equipment.

The solution:

- Neutron scattering: High precision phase diagrams
- Molecular surfactants control nucleation
- Simulate underwater conditions, provide total control.

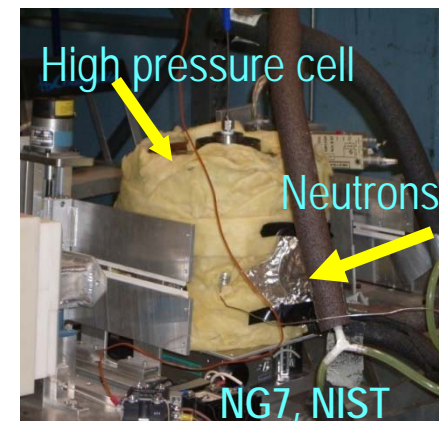

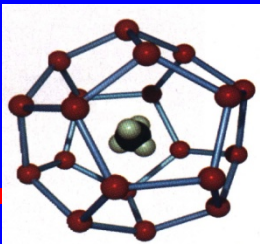

Methane Hydrates- Sediments Characterization

Pure Methane hydrate (without host sediment)

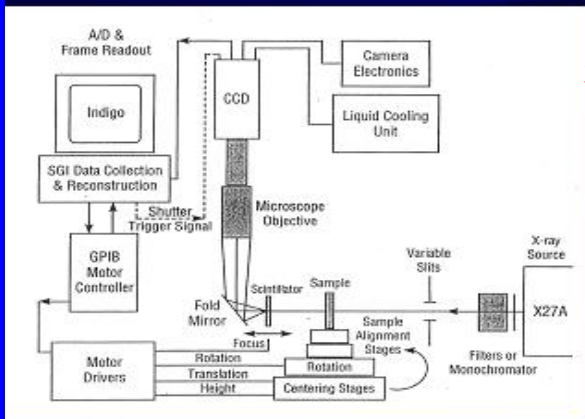

SI

Beamline X27A at NSLS,

Brookhaven National Laboratory

- X-ray energy in the range of 10 to 50 keV
- Various metal filters to vary energy and resolution
- X-rays pass through sample and are converted to visible light by a cesium scintillator
- Digital camera records visible light signal which is a function of x-ray absorbance.
- Images collected as sample rotates 180 degrees
- 3-D images reconstructed from 2-D images.

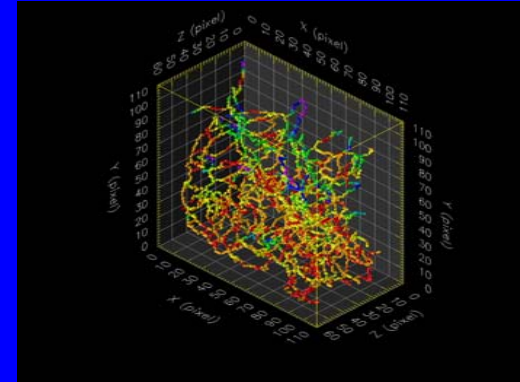

3-D CMT Data at NSLS

Advantages

- Resolution of 3.4 to 6.8 microns
- Permits 3-D imaging of opaque components in earth materials
- View components in situ
- Permits examination of 3-D porosity distribution, shape and connectivity

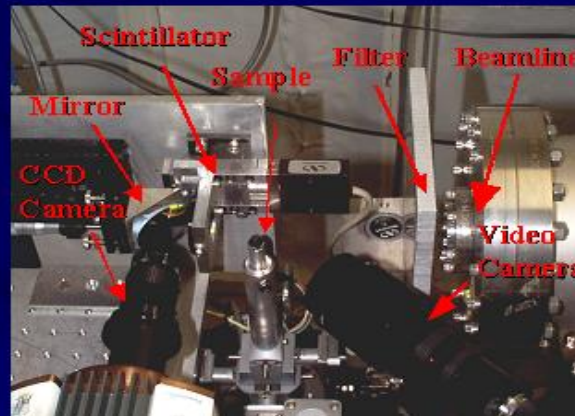

Polymers for Energy

Polymers are an enabling technology implicated in diverse applications.

- **Proton Exchange Membrane Fuel Cell:**

Current is produced when charged Nafion polymeric membranes allow diffusion of H⁺ ions to the cathode. MRSEC researchers developed new thiol functionalized Pt or Pd nanoparticles films which increased power production by more than 30%.

- **Carbon-polymer nanocomposites:** MRSEC

researchers have demonstrated that carbon nanotubes can be electrospun into nanofibers which are ultra strong and lightweight, conducting and fireproof. Millions can be twisted together to produce low loss cables for high current applications.

- **Supercritical carbon dioxide processing:** MRSEC

research has found new regime in supercritical CO₂ phase diagram where it becomes a universal solvent. Potential for green, low energy processing and cleansing of LNG transmission networks.

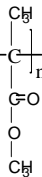
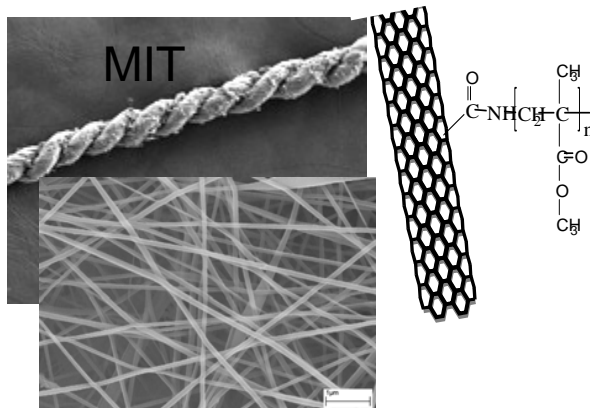
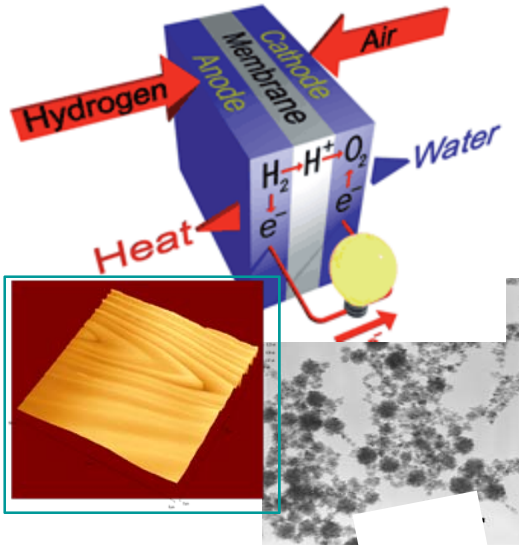

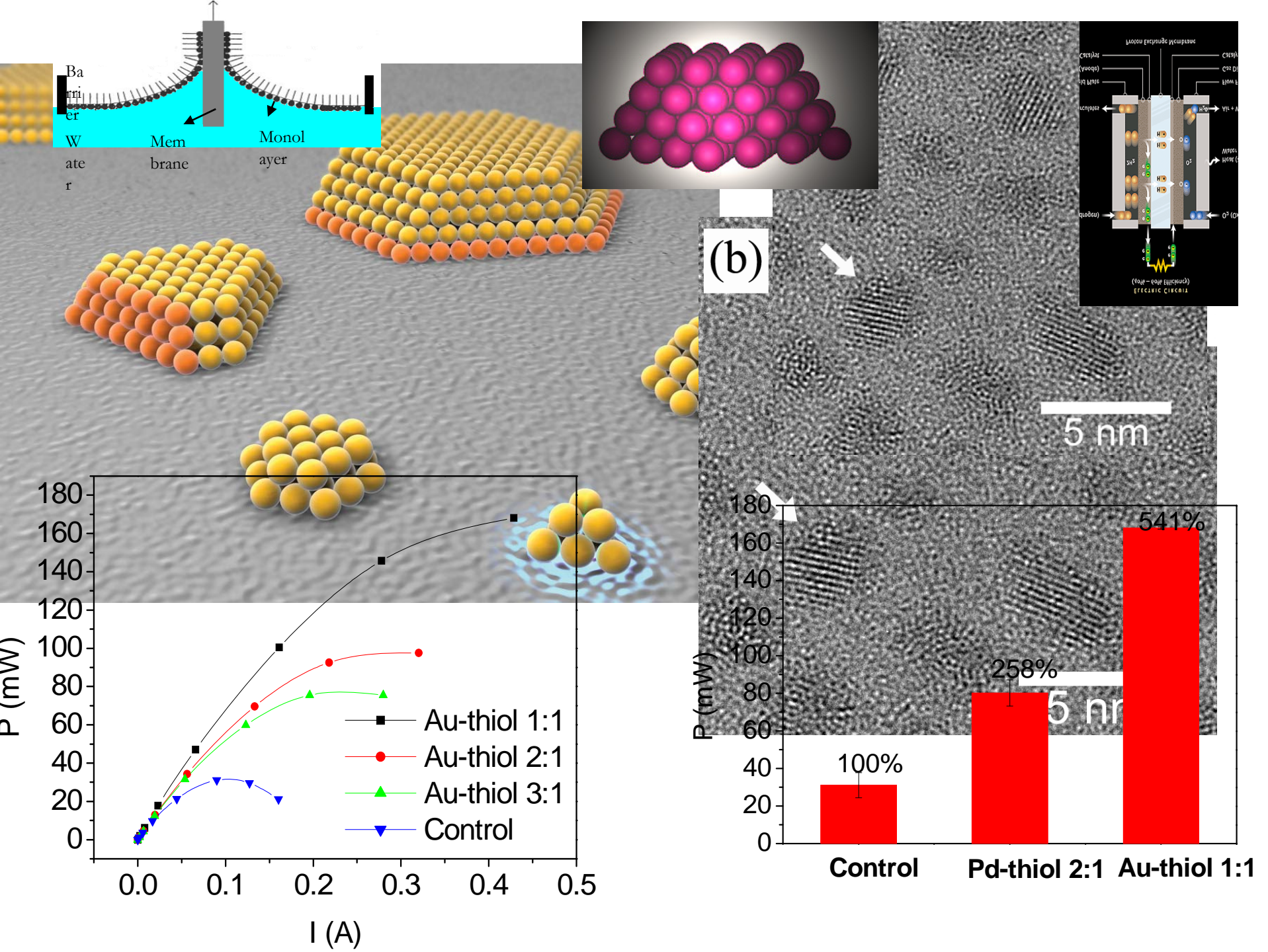

Ex: Wastewater Generation in Navy Ship

300-man ship: 16,000 gal/day ~ 66 ton/day

- Black water (sewage) : 6,000 GPD
- Gray water (kitchen, showers, laundry) : 4,000 GPD
- Bilge water (bilge) : 6,000 GPD

80% reduction in power for membrane processing method vs. other methods

Energy saved by a factor of ~20

EX: single stage RO plant with Diesel Gen-set

1-lb water purification – 56 BTU (British Thermal Unit)

**With high flux thin film composite membrane
20-lb water can be purified with the same power**

New approach for high flux membrane

Thin layer of smooth hydrophilic cross-linked polymer
(e.g. Chitosan, Poly (vinyl alcohol), Polyamide)

~100-nm/1- μ m diameters highly porous electro-spun nano-fibrous membrane
(e.g. Polyacrylonitrile, Poly (vinyl alcohol))

Three-Tier Approach

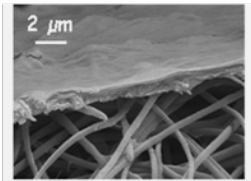

Fractured top coating layer edge

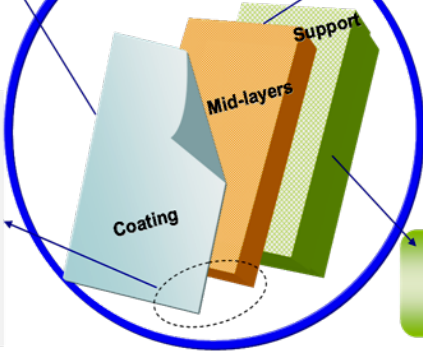

10- μ m diameter non-woven Polyester micro-filter

~20 times higher flux than conventional membranes

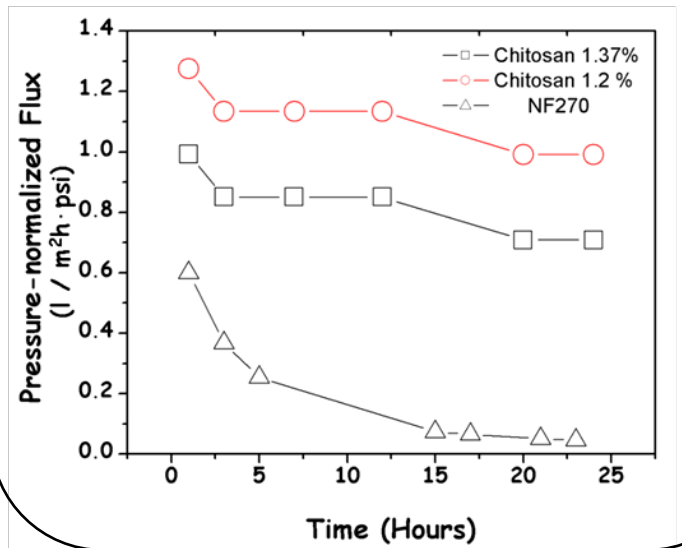

Plastics Recycling

● Plastic recycle industry



Melt Mixed

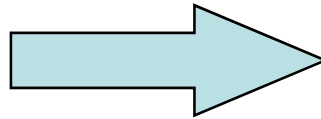

Clay

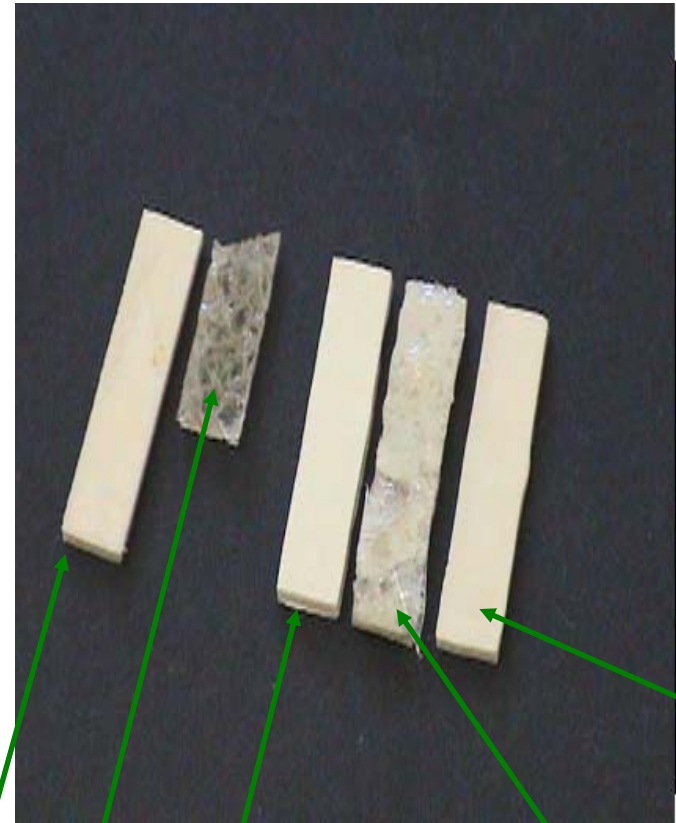
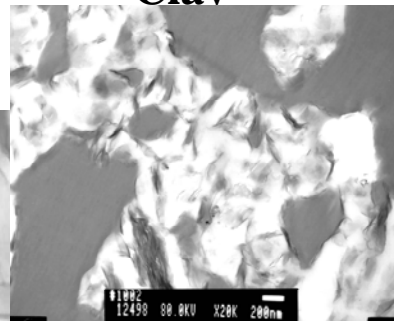

PS/PMMA
PETE/C

PS/PMMA/C20A PS/PMMA PS/PMMA/PET/C20A/C6A PS/PMMA/PET

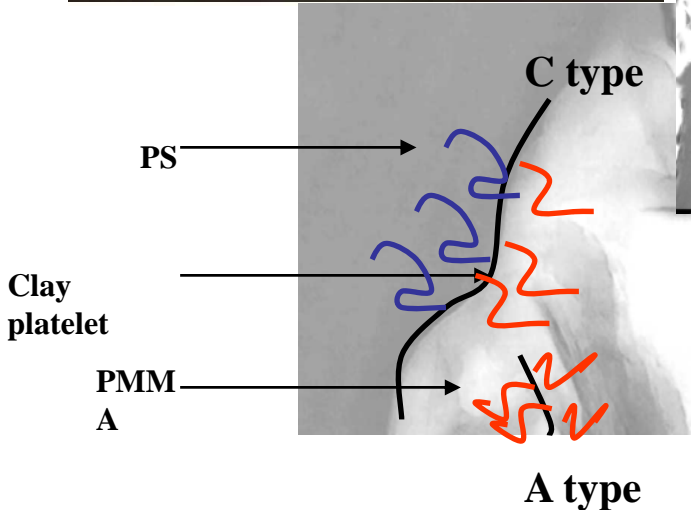

$$\alpha = \left(\frac{5Eh}{4(\gamma - \gamma')} \right)^{1/4}$$

Conventional Energy Project: Smart Grid

- Critical first step in power conservation is to maximize the efficiency of the power distribution system
- SBU, BNL , Blue Gene consortium and SUNY Maritime are applying their high level computational techniques to evaluate power distribution networks, and to design “smart grids” capable of making decisions to remediate local failures in nodes and to optimize distribution when cogeneration from multiple sources is activated.



Super-tough materials using biomimetic principles

(1)

□ Bead-spring model for polymer

- Lennard-Jones potential between monomers

$$V_{LJ} = 4\epsilon \left(\left(\frac{\sigma}{r} \right)^{12} - \left(\frac{\sigma}{r} \right)^6 \right)$$

- FENE potential connecting monomers on a chain

$$V_{CH}(r) = -\frac{1}{2}KR_o^2 \ln\left(1 - \left(\frac{r}{R_o}\right)^2\right)$$

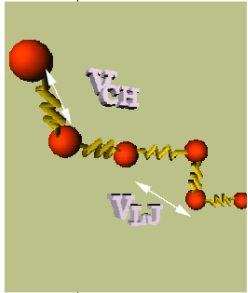

MD simulations of failure in polymer nano-composites

(3)

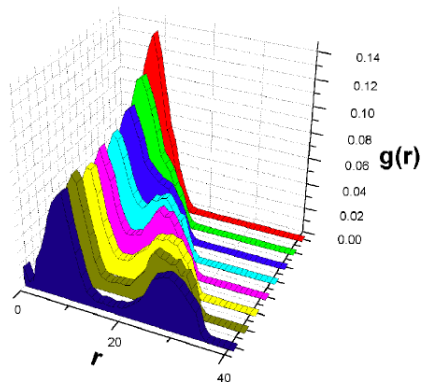

- Failure occurring by cavitation as two peaks appear in $g(r)$
- As the walls get pulled further apart there is always nanofiller present in region that bridges the cavity
- The ability of the nanofiller to participate in the deformation controls the toughness of the material

(2)

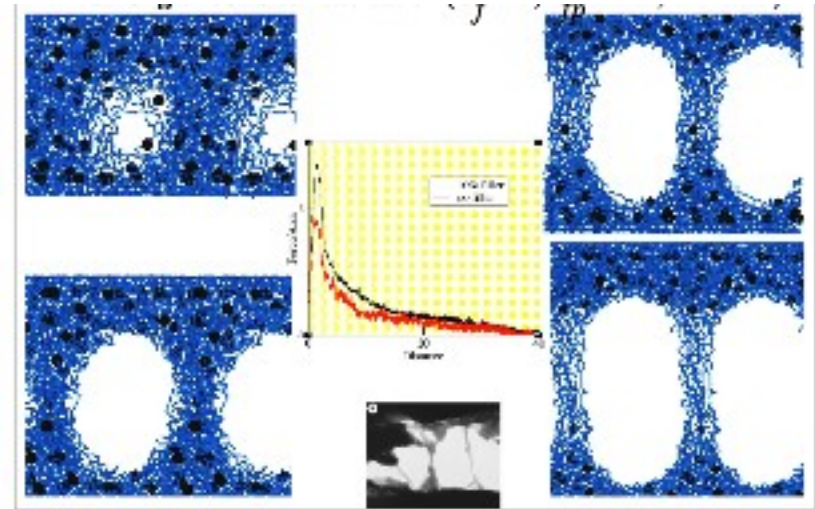

Polymer nano-composites show similar behavior to naturally occurring materials

(4)

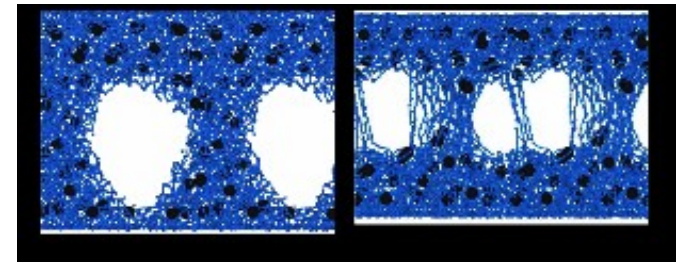

Super-toughening occurs only above T_g
-- effect of fillers related to filler mobility

Improving processability and wettability of materials

(1)

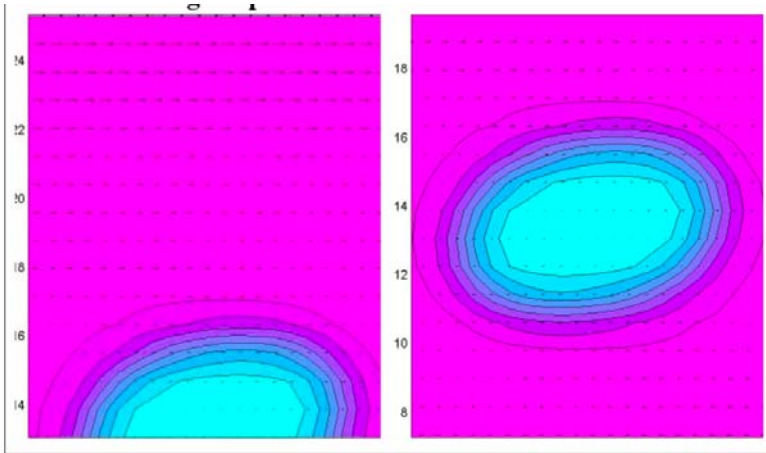

Reduce energy cost of processing --
polymer blends under shear

(3)

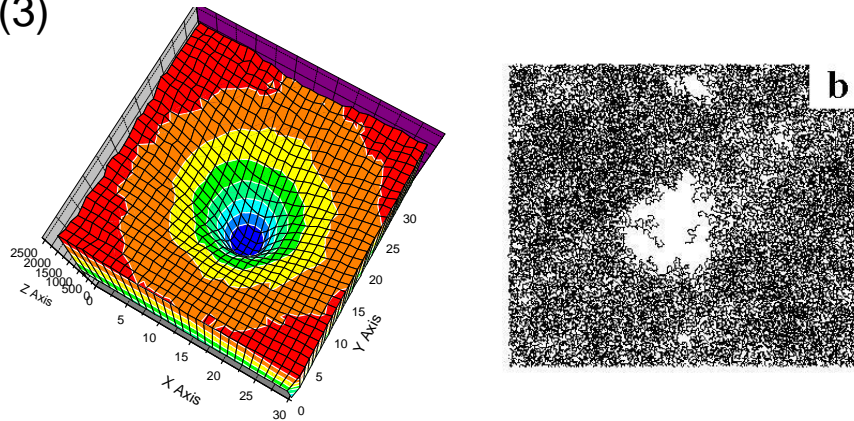

Stability of thin films -- lubrication
applications

(2)

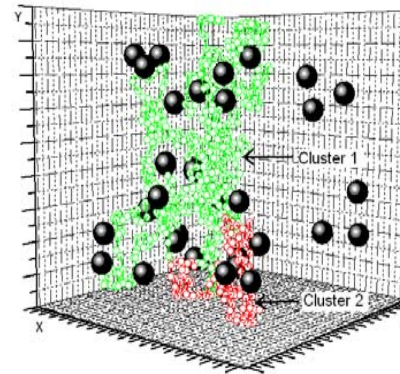

QuickTime™ and a
TIFF (LZW) decompressor
are needed to see this picture.

Rheology of polymer nanocomposites --
percolation & flow

(4)

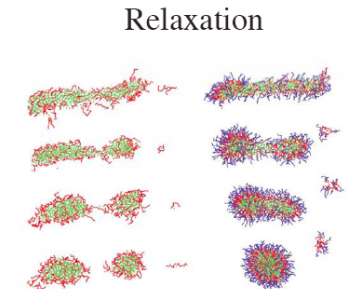
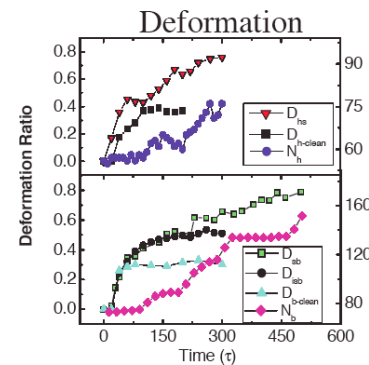

Emulsions and surfactants in shear flows --
improving mixing

How do they work?

Source: http://www.ceficefra.org/frames/f_how_fr_work.html?how_fr_work.html

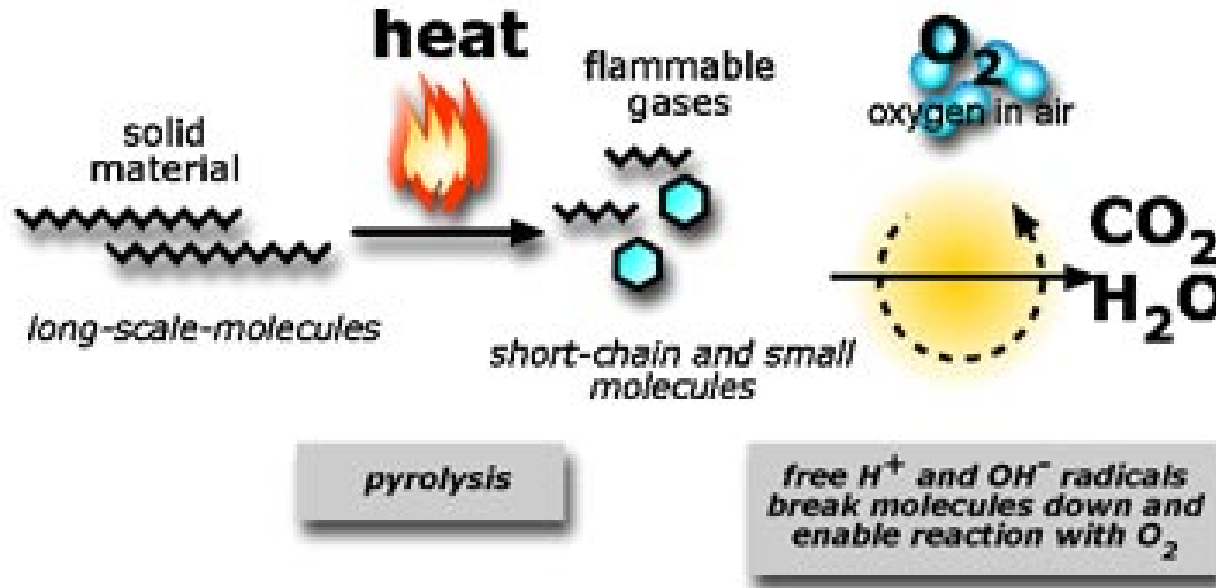

- Polymers are decomposed by pyrolysis and emit hot flammable gases.
- These gases contain H and OH radicals, which react with oxygen in the air to “burn” to CO₂, emitting heat.

Flame retardant and Self Extinguishing Materials

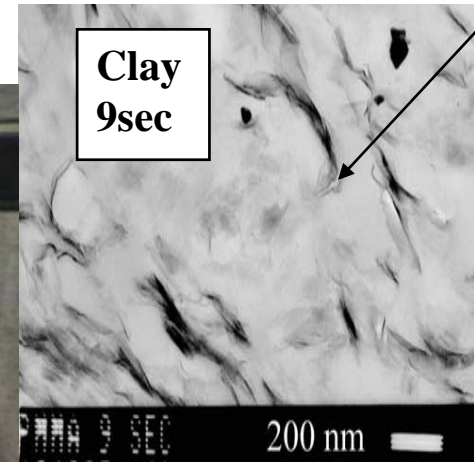

Engineered Nanocomposite
Polymers that are tough,
conduct , and self-extinguish!

(UL94-V5)



Photovoltaics: TiO_2 particles

The Environment: *Social Responsibility*

- Large particles are Talc.
- Smaller ones (~10nm) are TiO_2 particles.
- Titanium dioxide is used in most sunscreens to help prevent UV radiation burns.
- Zinc is also used in sunscreens as a UV blocking agent.

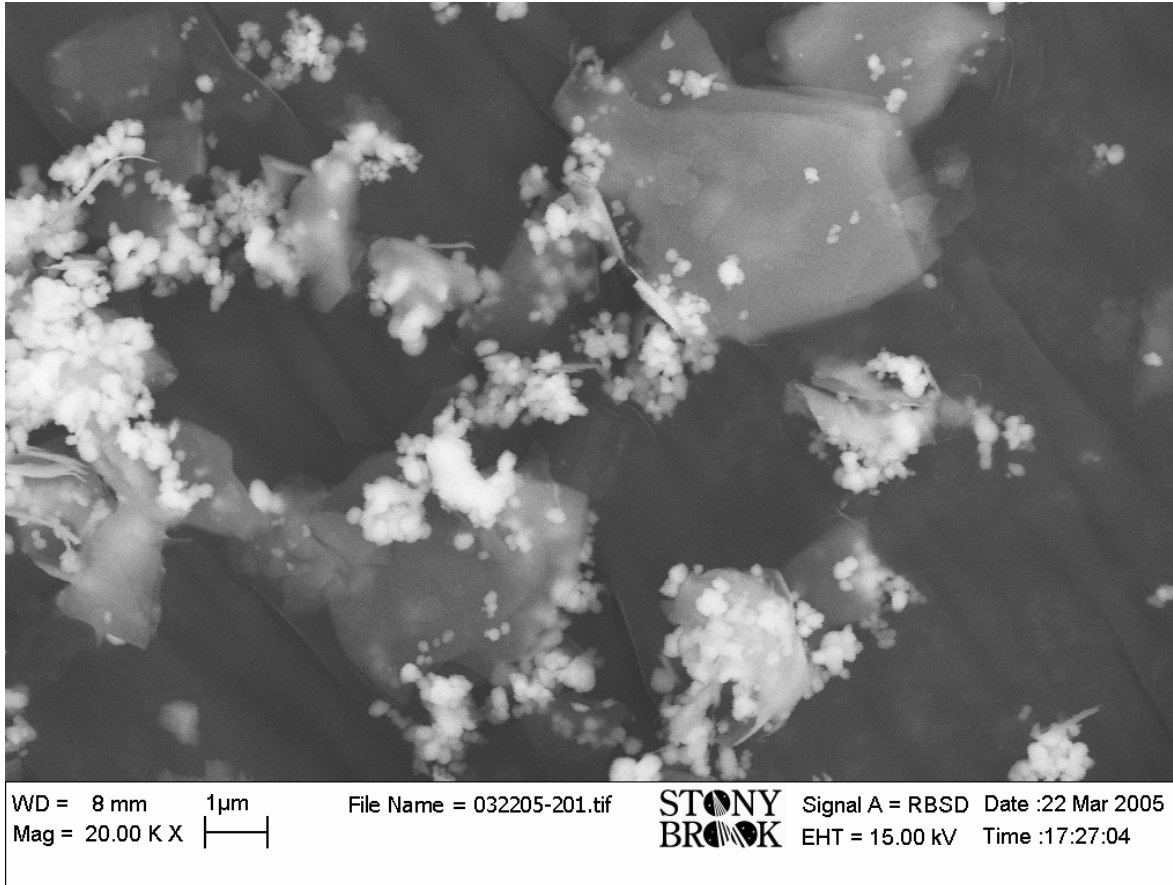

	λ DNA Non-exp	CT UVA 4h	TiO ₂ UVA 4h	coated TiO ₂ UVA 4h	CT UVB 4h	TiO ₂ UVB 4h	coated TiO ₂ UVB 4h	CT UVC 1h	TiO ₂ UVC 1h	coated TiO ₂ UVC 1h
--	--------------------------	-----------------	-------------------------------	---	-----------------	-------------------------------	---	-----------------	-------------------------------	---

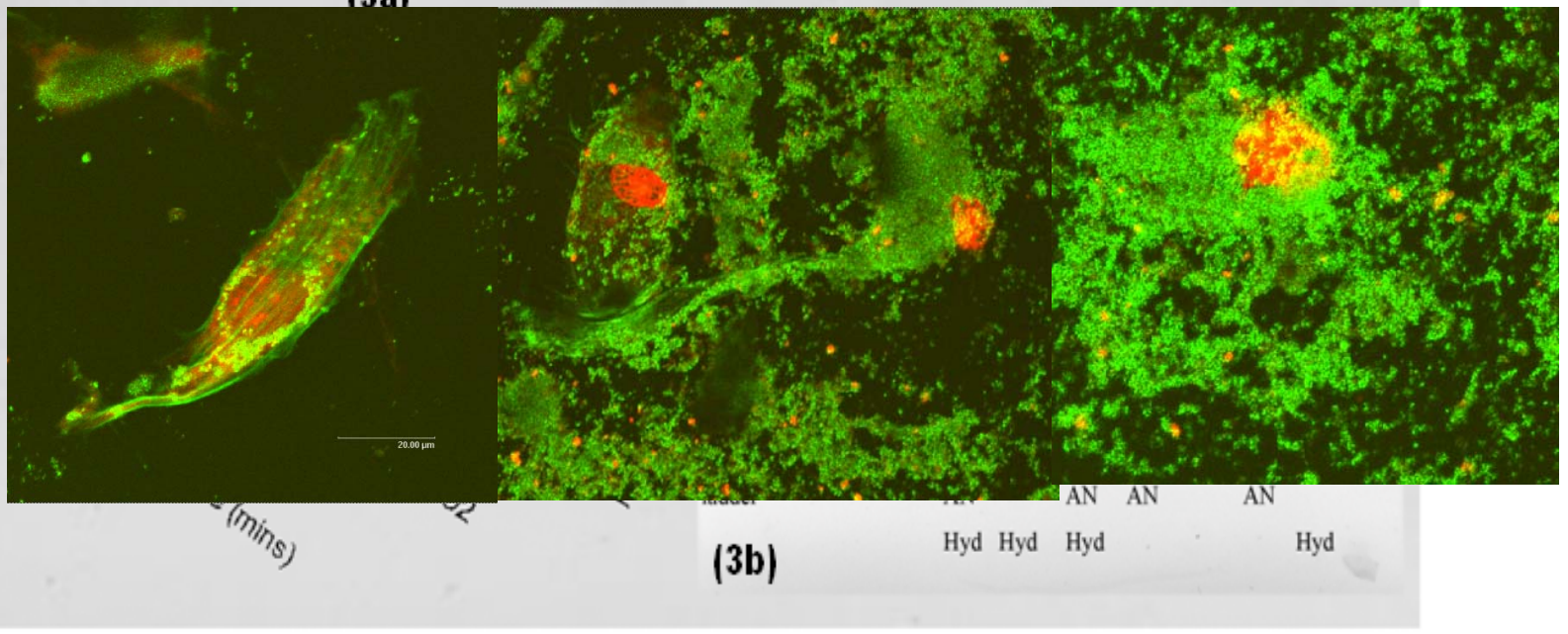
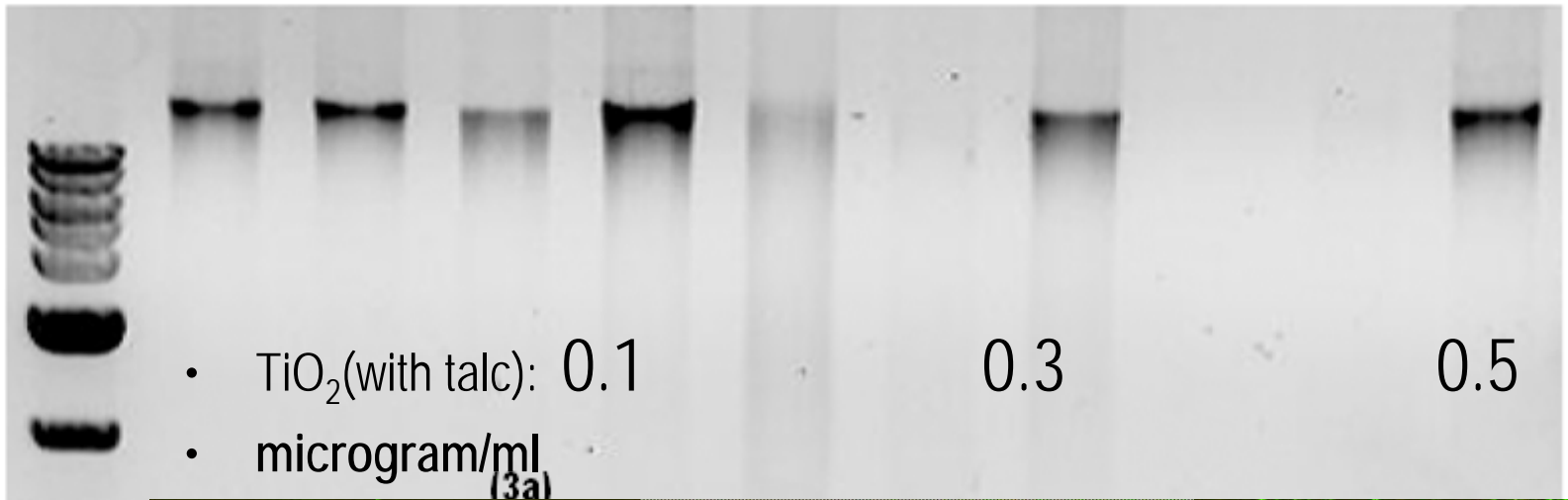



Osteoblasts cultured on EVA with clay and Fe₂O₃

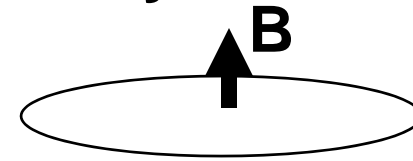

EVA+Clay/NO magnets

EVA+Clay/magnets

EVA+Clay+Fe₂O₃/magnets

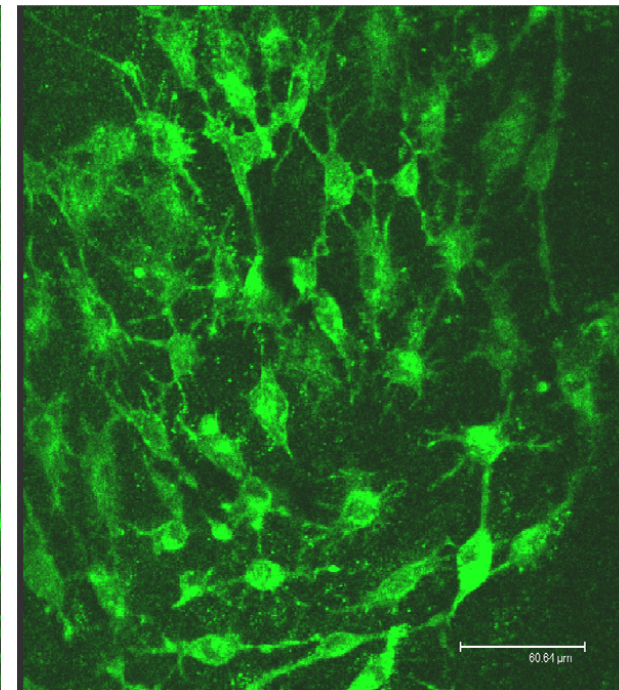
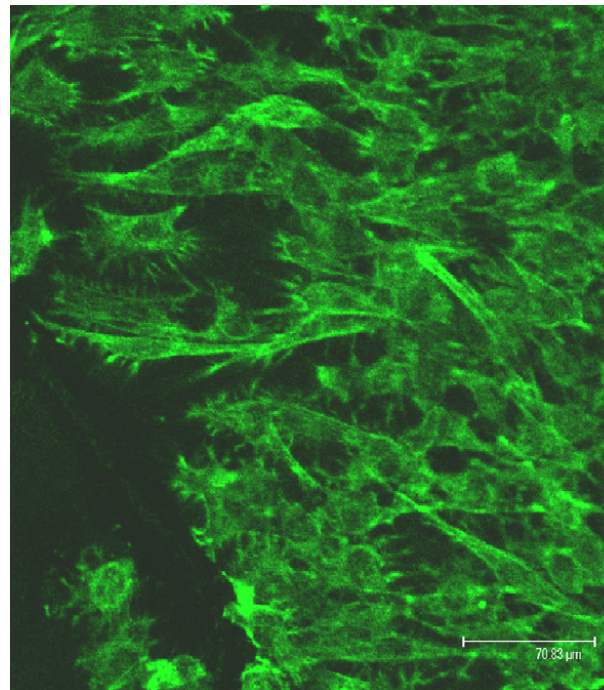
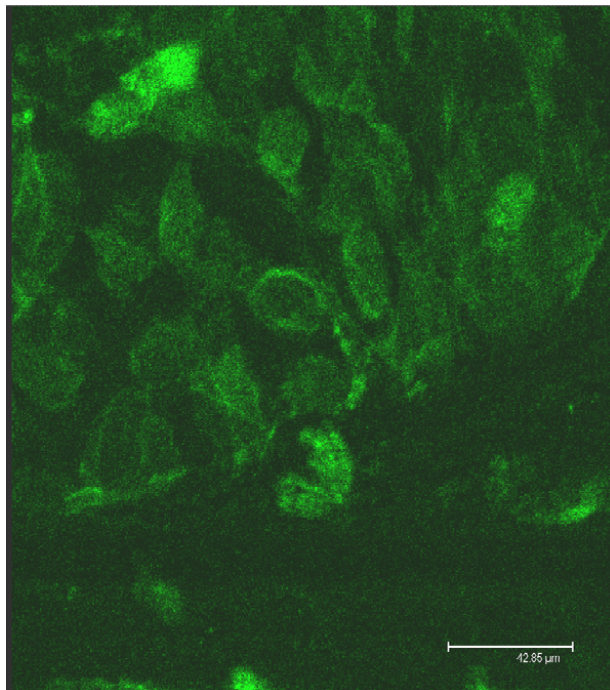

Tissue formation and cell orientation in external field.

Hydrogen Energy Solutions at the Nanoscale

A partnership between
Basic Energy Sciences and the Center for Functional Materials

Challenge: Meet Department of Energy Mandate to develop hydrogen batteries and fuel cells for powering cars, homes, and business by 2015.

Conditions: Produce materials that are inexpensive, safe to handle and dispose, and can be mass produced, which have high reactivity and capacity to store hydrogen.

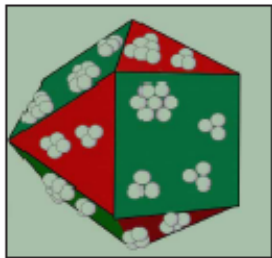

- Nanostructured catalysts: Nanoparticle Ru scaffold for Pt atomic Clusters. Pt atoms have the high catalytic efficiency, while Ru keeps the manufacturing costs low. Pt catalysts remove CO emissions for **clean and efficient burning of conventional fuels.**

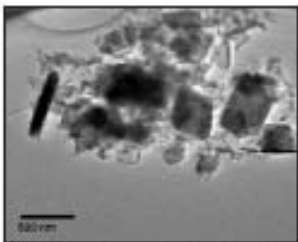

- LiAlH_4 Lithium aluminum hydrides *reversibly* decompose to form nano-platelets, 100nm thick. New type of electrodes for Li batteries **with extremely high efficiency for hydrogen storage and power generation.**

Biofuels Combustion at BNL

Focus on Stationary Applications

Combustion studies – boiler and turbines

Field Trials

Support for Codes and Standards

Properties

Storage and Thermal Stability

Burner Development

Blend Sensor

MicroCHP Engine Development

Ultra-high efficiency biofuel boiler

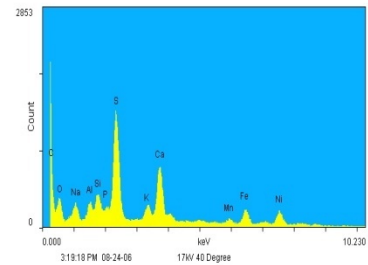
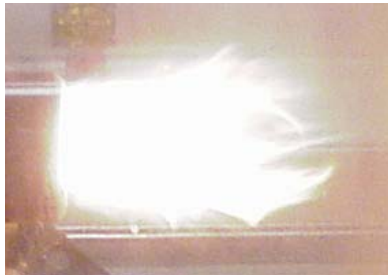

RFP

- \$50K/yr to fund joint collaborative research
- Areas related to energy
- Seed grant for future funding



Conclusions

- Please join us in the ribbon cutting ceremony tomorrow for a new center for Advanced Energy Research and Technology. The center is partnership between academic institutions, national laboratories, and industry.
- The mission of the center is to combine nanotechnology and engineering in order to (a) pursue cutting edge research on new and traditional energy sources, (b) establish demonstration sites to test and evaluate new technologies, and (c) increase public awareness of energy issues and policy through outreach and education programs